

Jumpboard for Rialto® Reformer

PARTS LIST:

DESCRIPTION	PART NO.	QTY
Rialto Jumpboard	620-102	1
Jumpboard Posts w/Detent Pins	620-082	2
1/4"-20 2-1/4" Screws	GEN7314	6
1/4"-20 Flat Washer	GEN9305	6
5/32" Allen Hex Key	GEN9282	1

Once you install your new Jumpboard the Posts will force the jumpboard away from the carriage just slightly. This auto-tilting will reduce any rocking of the jumpboard and noise during use. The detent pins are pre-installed in your posts, no adjustments should be necessary.

INSTALL JUMPBOARD POSTS

1. Lay the jumpboard cushion side down. Place a post on the back of the jumpboard such that the end of the post that hangs off the jumpboard will be opposite the handles. There should be a little ball facing up at the bottom of the post near the end of the tube, See Figure A.
2. Use the provided Allen Hex Key to install (3) screws securing the post to the back of the jumpboard.
3. Repeat for the other post ensuring the bottom ball is facing up.
4. Your Rialto Jumpboard is now ready to use.

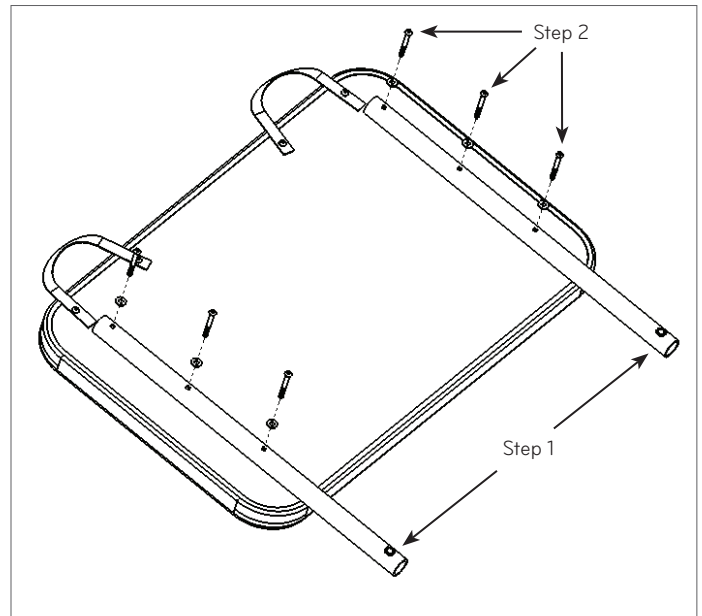

Figure A

Questions? Call Balanced Body Technical Support at 1-800-PILATES (US and Canada), or +1-916-388-2838 (all other countries).