

Carriage Pad Replacement for Rialto

PARTS LIST:

ITEM	PART NO.	QTY
Carriage pad	620-079	1
Nylock nut	GEN7553	7
Washer	GEN9305	13
#10 Wood screw	GEN9143	6

Tools Required (Not Included)

- » 10mm box wrench
- » Phillips screw driver or drill with no. 2 Philips bit (recommended)

1. Remove the loops and ropes from the carriage. Unhook the springs from the spring bar hooks. Flip the carriage over and lay the carriage on a smooth, clean surface with the upholstery side down. The carriage can also be flipped over and laid across on the reformer frame.
2. Remove the springs from the spring bracket under the carriage.
3. Using a 10mm wrench, remove the (4) nylock nuts that hold the carriage rails to the carriage pad, remove and discard the nylocks and the washers. See Figure A for a closeup of which nuts and washers need to be removed. See Figure B for all (4) locations.

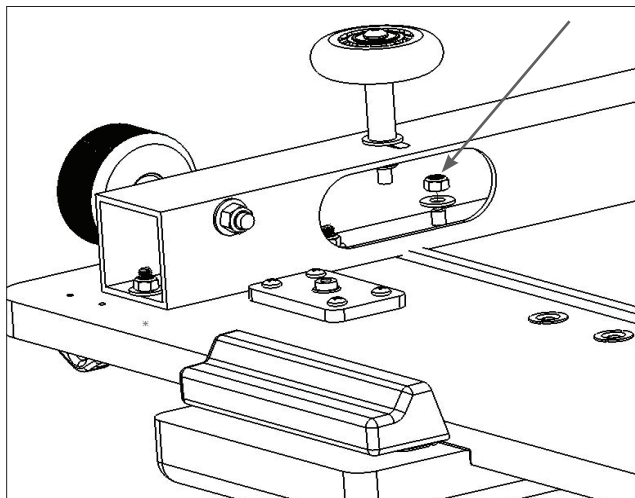

Figure A

4. Using the same wrench, remove the nylock nuts that hold the spring bracket to the carriage pad. See Figure B. Discard the nylocks and the washers

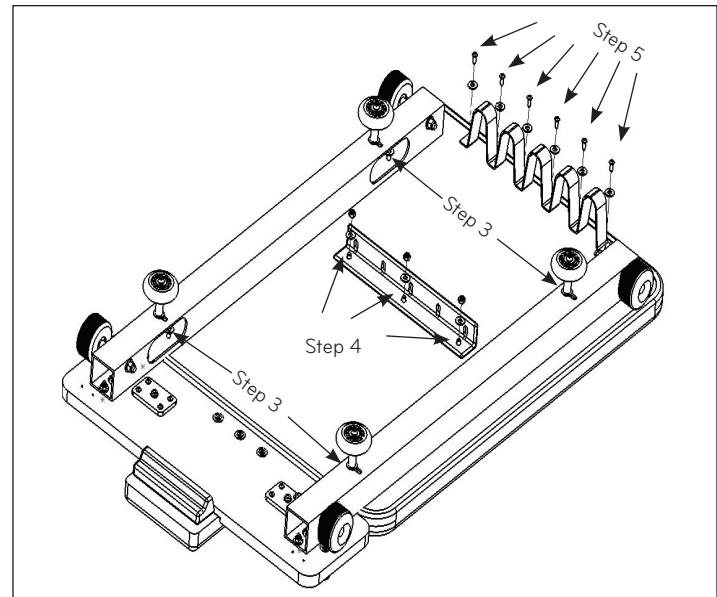

Figure B

5. Using a Philips head screw driver remove the (6) wood screws and washers that hold the spring sling to the carriage pad. Again, these screws and washers can be discarded.
6. Remove the old carriage pad by lifting the carriage rails and the head rest assembly up. Lay this carriage rail assembly on the back of the new carriage pad. The bolts in the carriage pad will go through the holes in the carriage rails.

Note - The bolts in the carriage pad are not symmetric. One set is closer to the end than the other. The bolts that are closer to the end will go towards the head rest.

- Using the provided nut, washer and wrench, fasten the carriage pad on to the carriage rails. Attach the spring bracket using the same method as the rails. Attach the spring sling to the carriage pad using (6) washers and (6) screws. The holes for the spring sling are predrilled into the wood already. Make sure all the nuts and screws are tight. See Figure C for reference.

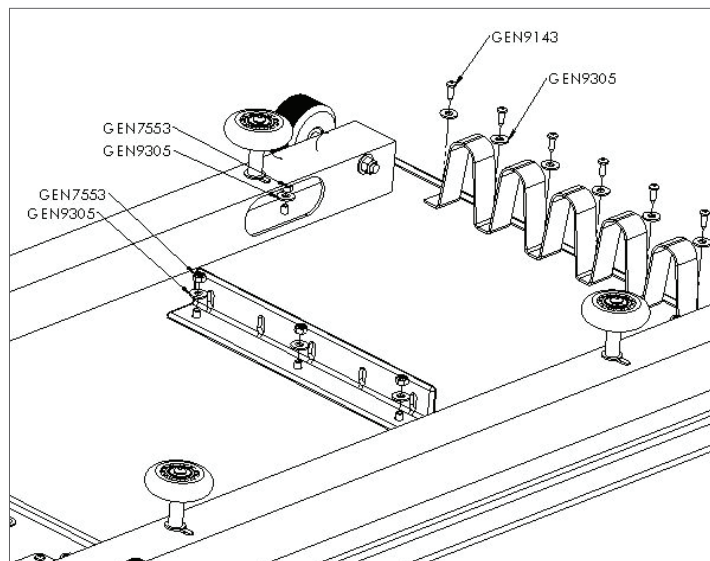

Figure C

- Clean all the wheels and frame rails with a clean cloth to ensure a smooth ride.
- Reinstall the removed springs onto the spring bracket. The open end of the hook will face away from the carriage pad back. The closed end will go through each spring loop.
- Carefully lift the carriage and flip it back over and place it onto the frame rail. Roll it back and forth a few times to make sure that the ride is smooth and no contaminants were left on the wheel or rails.
- Reinstall the ropes and the loops.
- Attach at least one spring to a spring hook to keep the carriage home.